

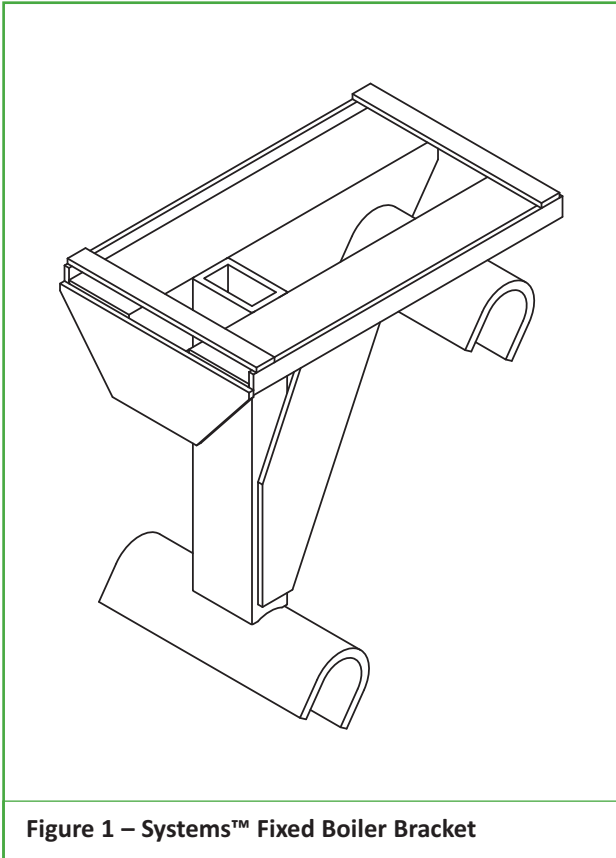

Systems™ Fixed Boiler Bracket Product Fact Sheet



Part No. & Description	SASB3 Systems™ Fixed Boiler Bracket
Weight	28.0 lbs.

Features and Benefits

- Specifically designed to be used on boilers with 55° throat walls
- Used with SBB6 base beam – this bracket will fit a 7' bay to incorporate a stair unit
- Only use with Safway swivel jack (SSJ)
- Allows full coverage of all standard Safway Systems™ Scaffold horizontal lengths
Note: When using the SASB3 bracket, it is recommended to bring spare adjustable SASB2s due to variations in boiler slope tubes
- All steel construction
- Hot-dipped galvanized
- Safway-engineered

Safway Services, LLC
Corporate Headquarters
N19 W24200 Riverwood Drive
Waukesha, WI 53188
Toll free: (800) 558-4772
Telephone: (262) 523-6500

For a list of branch locations in the United States and Canada, visit our website at www.safway.com

©2010 Safway Services, LLC. All rights reserved.

